

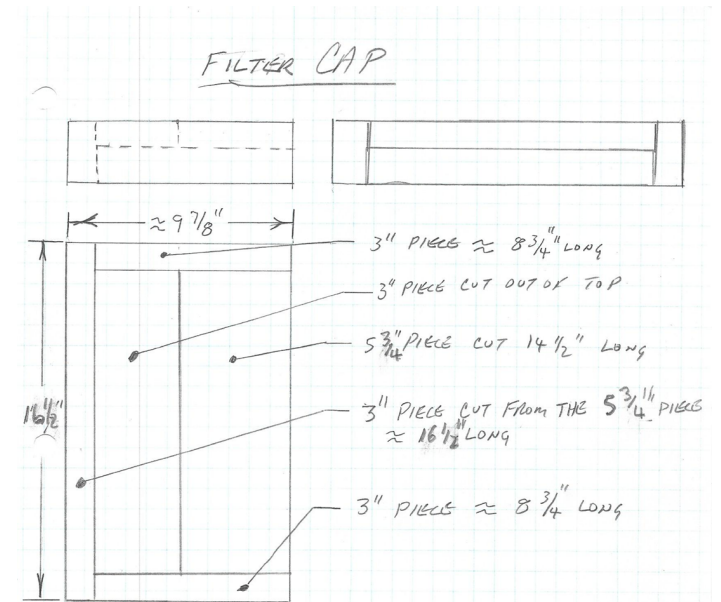
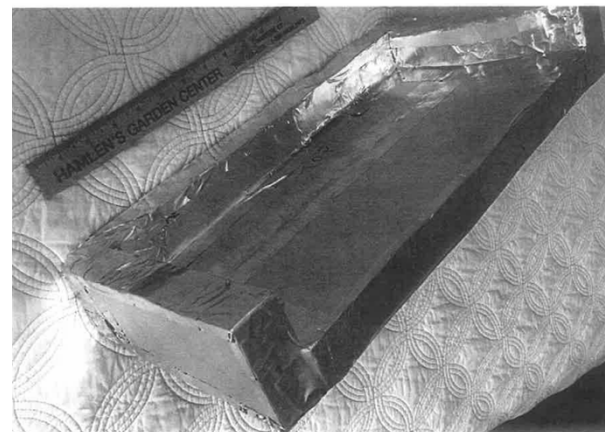
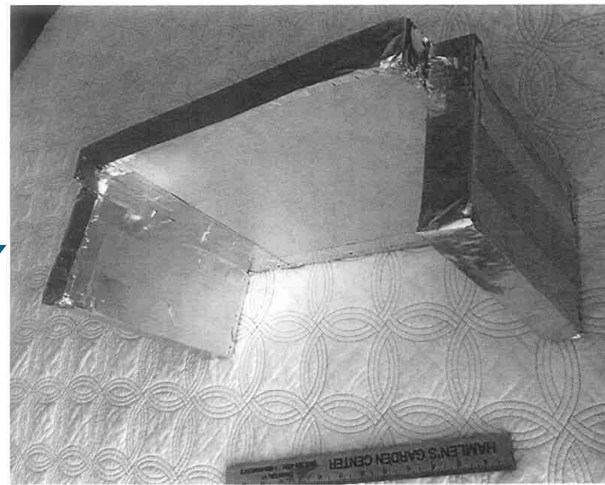
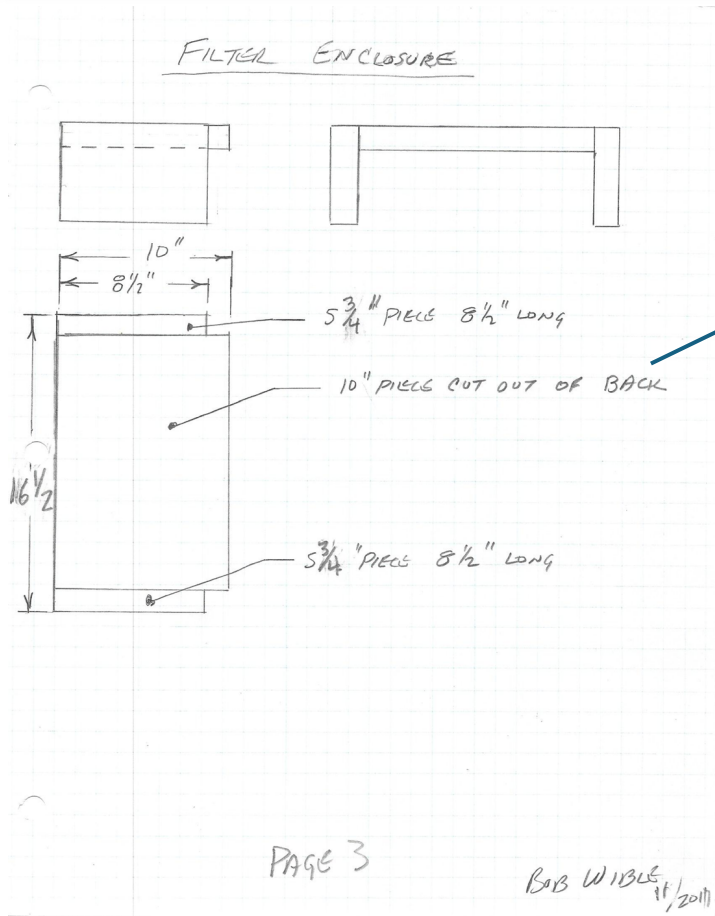
Trout in the Classroom

Tank Assembly Tutorial

Mark Manley
August 12, 2025; Rev 1



Insulation Panel Preparation & Dimensions



PAGE 4

BOB WIBLE 11/2011



Tank Assembly

- Step #1

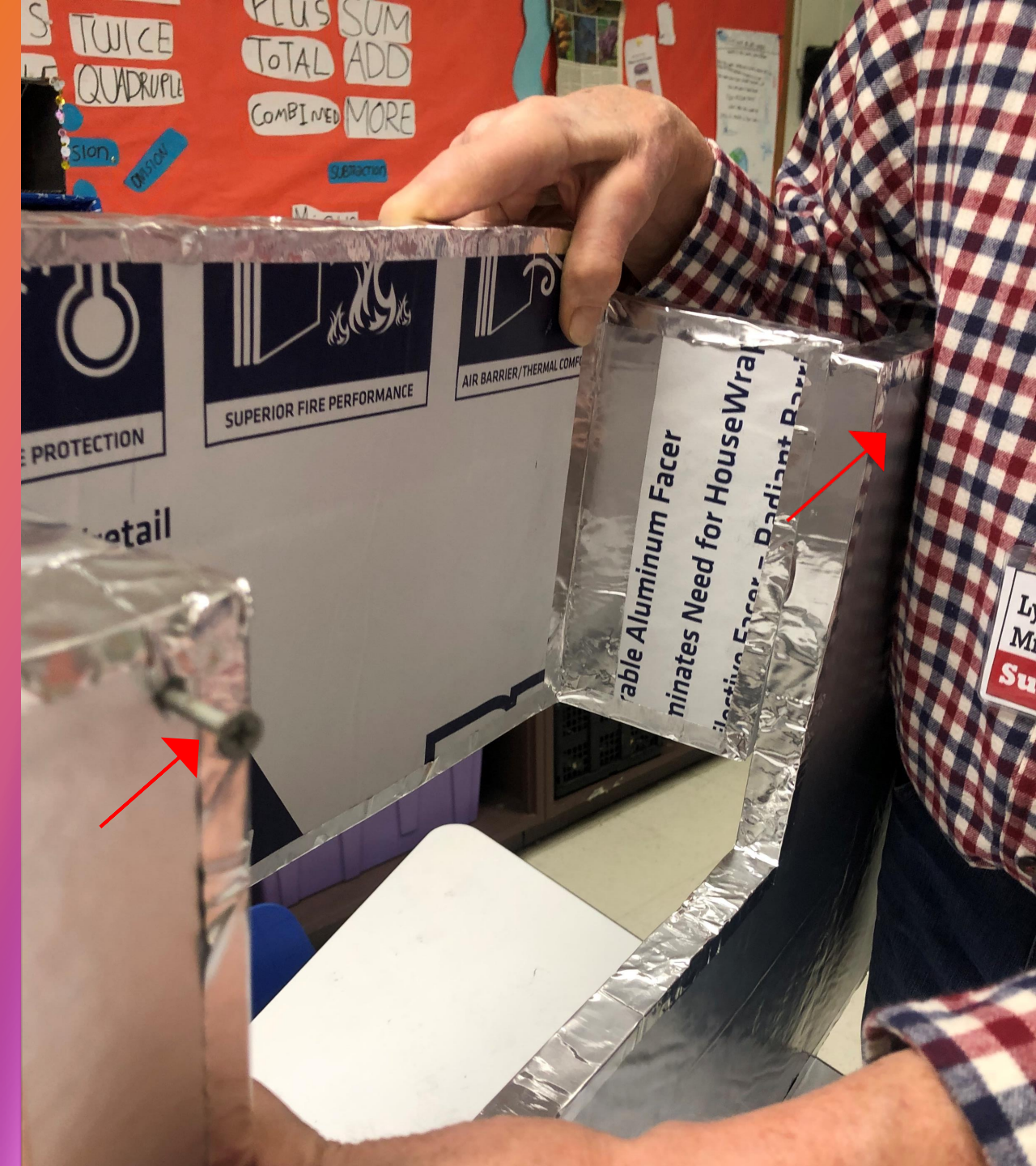
- Select sturdy table or bench (able to support 500 lbs) with close proximity to electrical outlet, and ideally, a water source for easy tank filling
- Make sure tank is clean!
- Center 55 gal tank on the foam insulation piece marked “bottom”
 - Leave sufficient room on backside so that filtration system can rest on the tank without touching the wall
- Wash gravel and place on tank bottom covering only half the bottom on the chiller side



Tank Assembly - Step #2



- Determine which end of the tank to place the chiller and filtration system - preferably close to an electrical outlet
- Orient foam insulation panel marked “Back” such that cut out is on the side that the filter will be located. Tape back panel to bottom panel.
 - You can modify the back panel by making a similar cut out on the opposite side if necessary.
 - Tape cut out piece to the cut out that won't be used

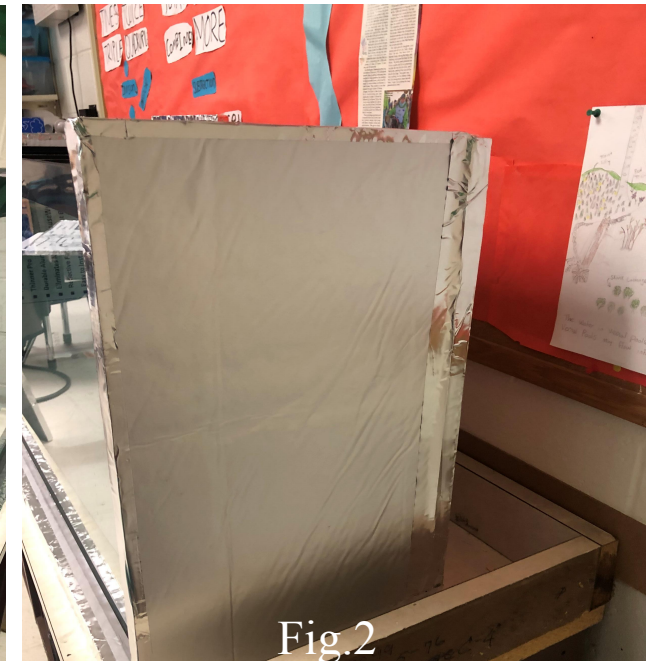
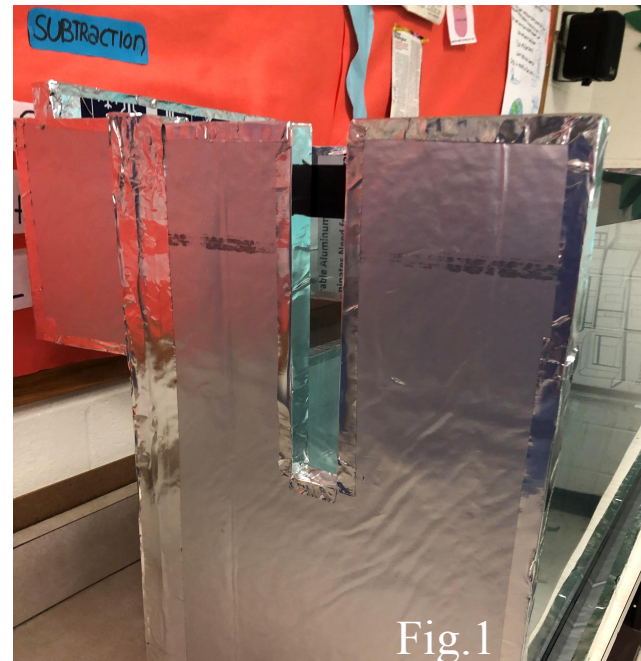


Tank Assembly - Step #3

- Attach filter enclosure to back panel cut-out using two (2) 4" screws.
 - Tape seams using metal tape
- Enclosure lip should be pointing up
- Top of the enclosure sides should be even and flush with the back insulation top edge
- Make sure enclosure is positioned on the back panel so that the filter can be placed on chiller back side of the tank

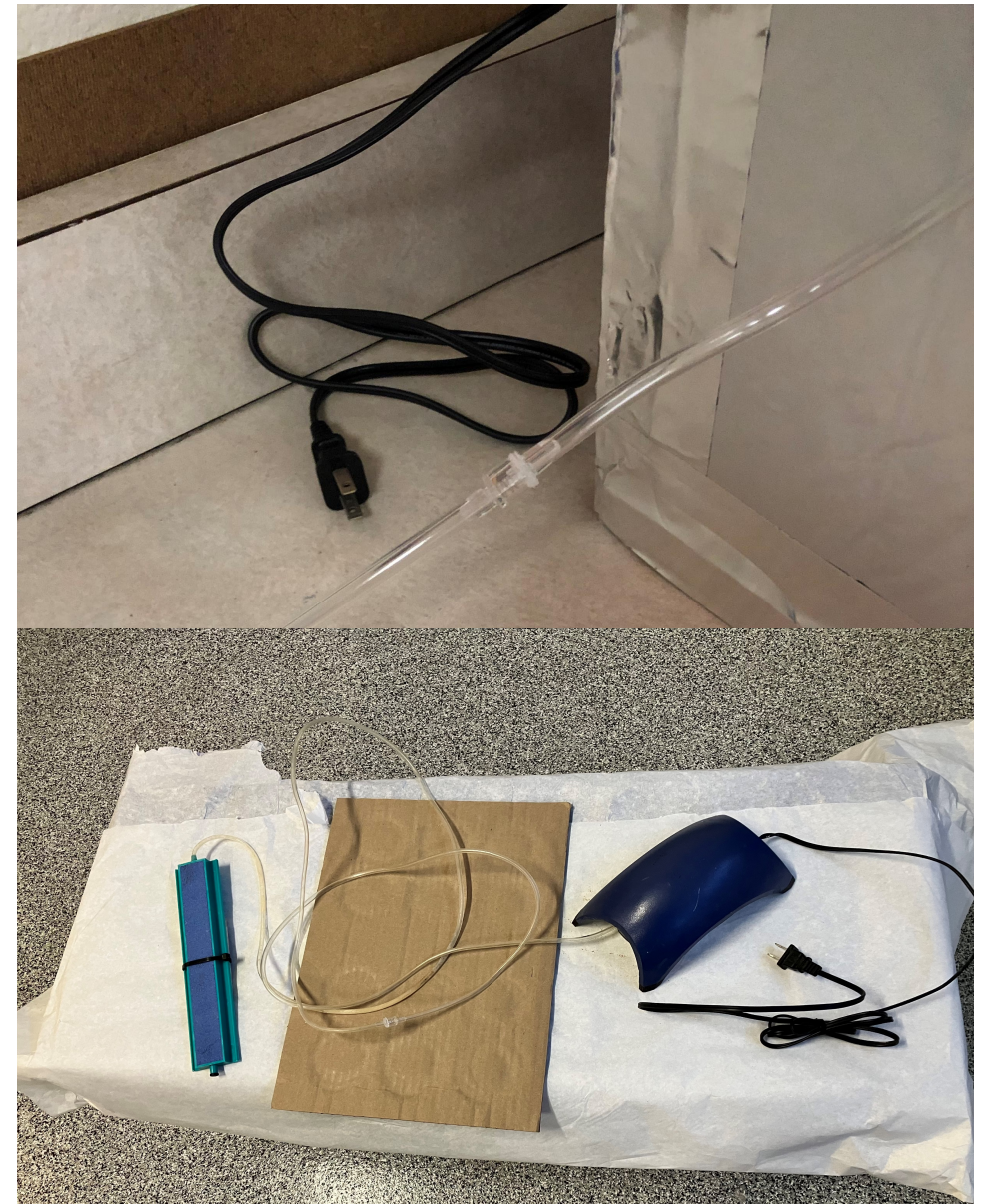
Tank Assembly - Step #4

- Install foam insulation end so that slotted end is where chiller will be located. [Fig.1]
- Install other foam insulation end and tape up all seams on both ends using aluminum tape [Fig.2]
- Assembly through step 4 should look like this [Fig.3]



Air Pump & Air Stone Assembly- Step #5

- Connect air pump and air stone with air line tubing
- Identify air flow direction in check valve by looking for arrow or sucking through the valve. The direction where the air flows needs to be oriented such that air is flowing to the air stone.
- Cut air line and install check valve based on air flow to air stone
- Add weight to air stone using zip tie and place on gravel directly below where chiller coil will reside
- Position air pump on chiller side of the tank
- **DO NOT TURN PUMP ON UNTIL TANK IS FILLED AND AIR STONE HAS SOAKED FOR AT LEAST 20 MINUTES**



Water Filter System Assembly - Step #6

- Always consult manufacturers assembly instruction
- Reference video below for assembly [Fig.4]



Fig.4

Water Filter System Assembly - Step #6 (cont'd)

- Reference video on how to assemble foot to bottom of filter housing/body to ensure that it rests level when hung on the tank [Fig.5]
- Zip tie a piece of window screening to the opening of the filter that will be submerged in the tank water so fish do not get caught in it. [Fig.6]

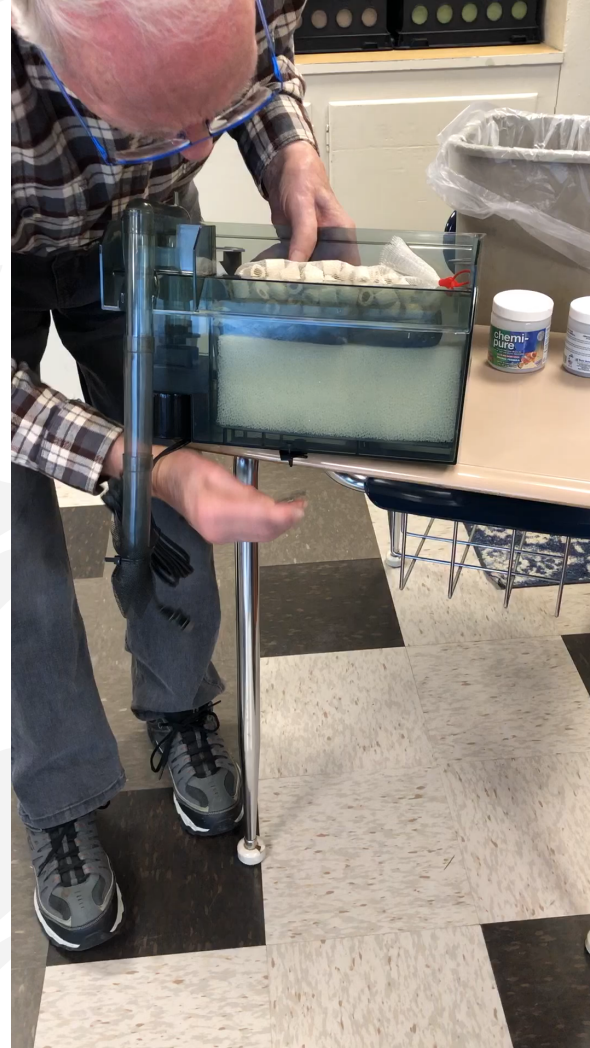


Fig.5

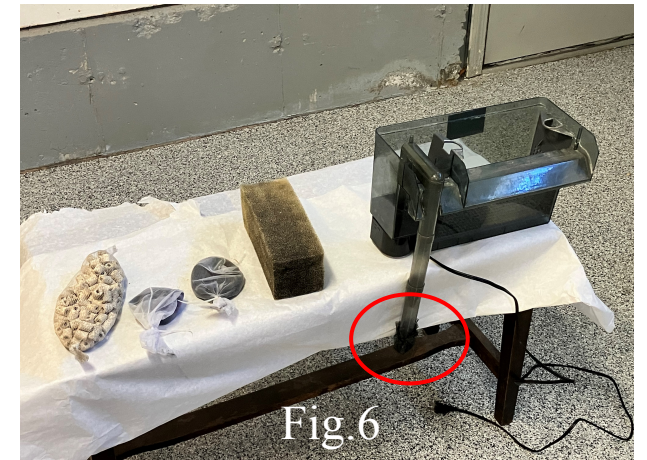
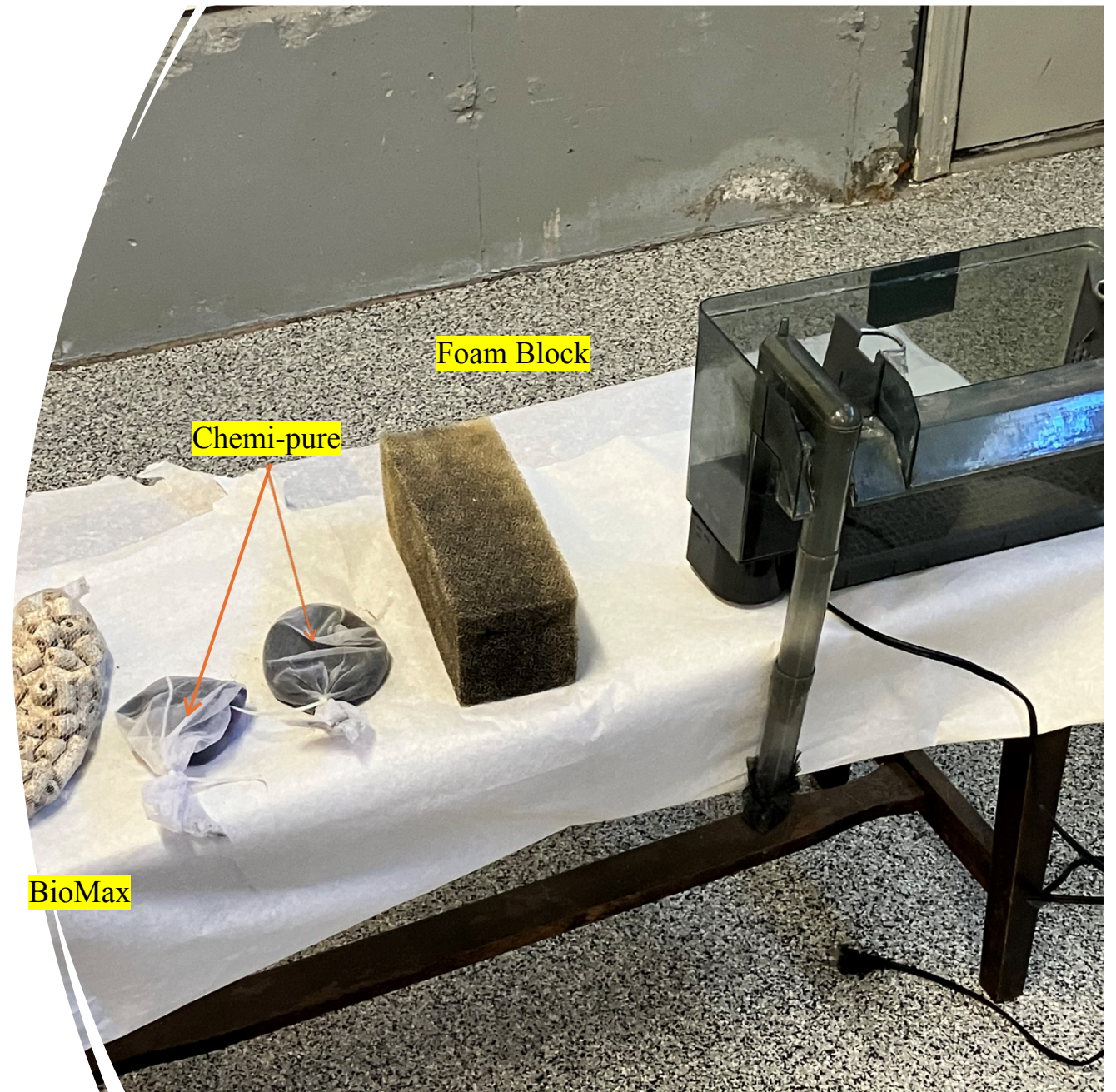


Fig.6

Water Filter System – Step #6 (cont'd)

- Hang filter on tank back in opening of back insulation. Feed filter power cable through bottom of filter enclosure
- Place foam block on bottom, position 2 bags of washed Chemi-pure on top of the foam block
- Shake out BioMax over a trash can, place into the netting bag provided and set on top of Chemi-Pure
- Fill tank with water and add appropriate amount of water conditioner



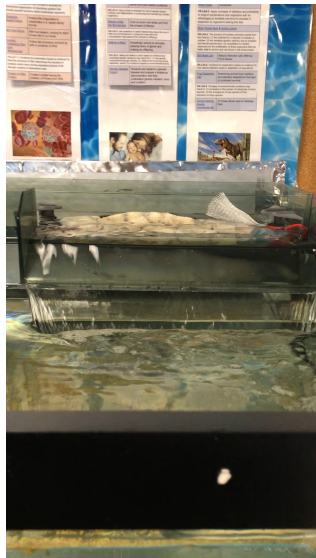


Fig.7

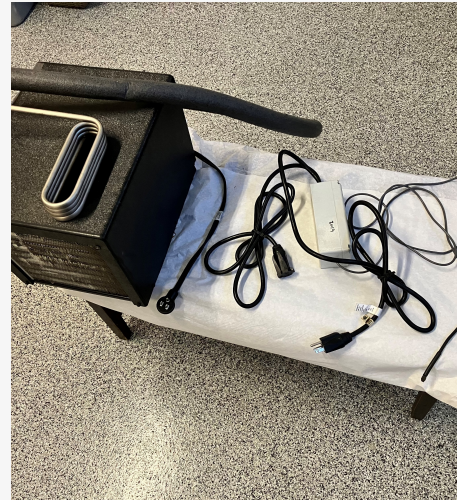
Water Filter System Assembly - Step #6 (cont'd)

- Scoop some water out of the tank to prime the filter cavity
- Plug filter into electrical outlet and make sure water is moving through it [Fig.7 - video]
- Install filter cover

Fig.8

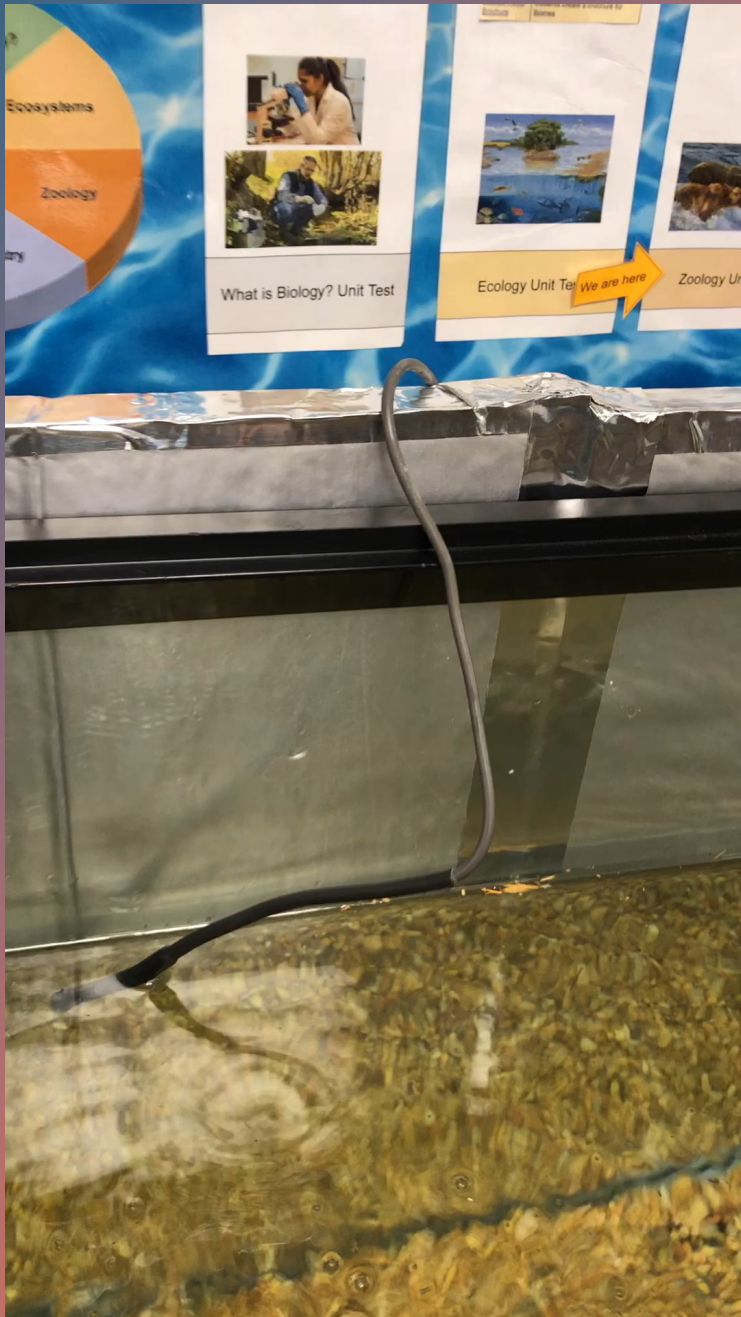


Fig.9



Chiller System Installation

- Position chiller unit on tank side and slide drop-in coil into the tank using the slot in the side panel [Fig.8]
- Make sure air stone is directly below chiller coil [Fig.9]



Chiller Sensor

- Place chiller sensor at least 2 feet from the chiller coil.
- Cut slot into back panel so that sensor does not affect placement of the top panel
- Tape sensor cable to backside of back panel
- Plug sensor controller into chiller and then into electrical outlet
- Place sensor controller on top of chiller

Breeder Basket Modification

WHAT YOU NEED:

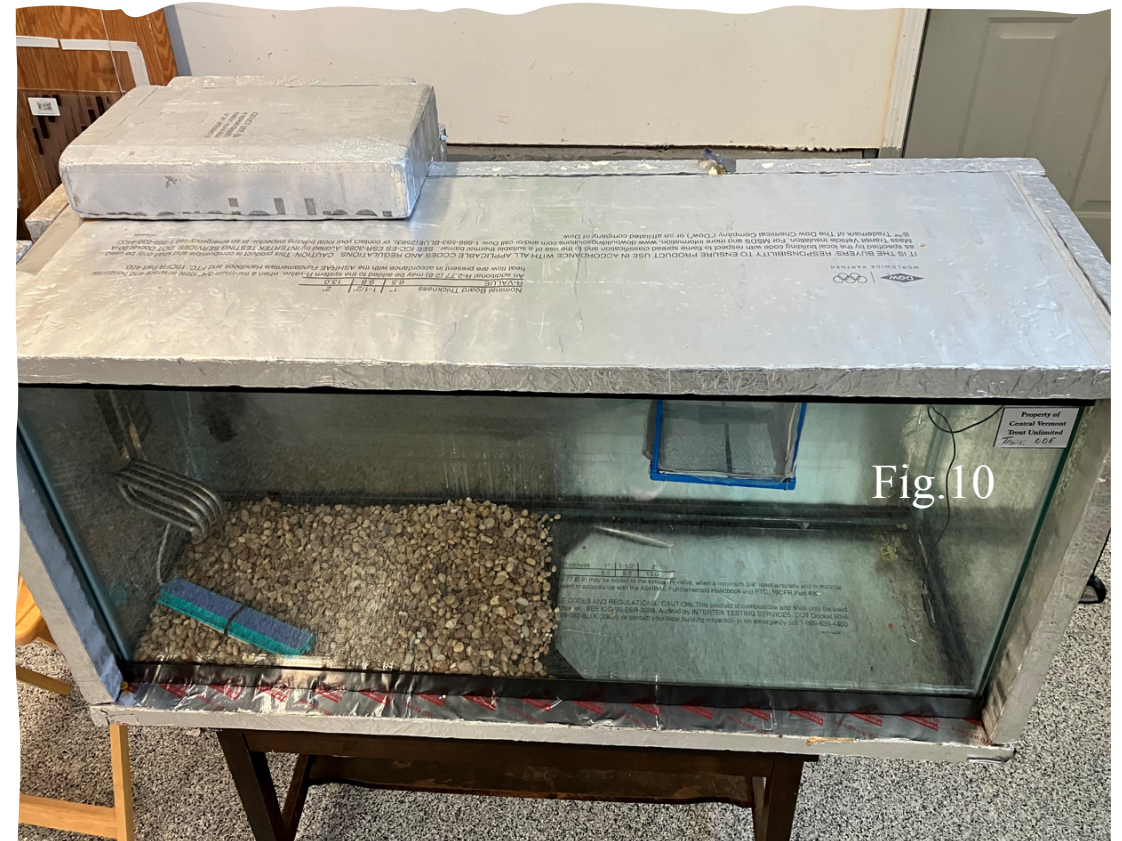
- Net breeder basket
- Aquarium caulk (cement)
- Scissors
- Fiberglas screening 4 ½ x 6 ½
- Plastic wrap
- Alum wire 18 gauge

PROCESS:

- Assemble basket frame.
- Place large piece of plastic wrap on bottom outside of frame (to protect it from the cement).
- Place net on frame so that the wrong (unfinished) side of the net is on the outside. Pull loop on net tight so net stretches over frame.
- Set assembly upside-down, bottom pointing up.
- Squeeze a continuous bead of cement around edges of bottom.
- lace piece of screening on the cemented area.
- Lay another piece of plastic wrap on top of screen.
- Turn complete assembly over onto hard flat surface and press on cement bead to flatten it.
- Let cement dry for 24 hours.
- Remove net from frame and take off both sheets of plastic wrap.
- Let cement dry for another 24 hours.
- Cut original bottom netting away from bottom of newly installed screening.
- Wire bottom corners of modified net bag to inside bottom-corners of frame.

Chiller System Completion

- Place air pump on top of chiller unit and plug into electrical outlet
- Make sure air stone is directly under the chiller coil
- Attach breeder basket to front edge of tank in the end away from the chiller coil [Fig.10]
- Install top insulation panel
 - May need to notch it out to make room for chiller hose
 - Tape chiller coil slot to keep light out
- Install filter housing cover insulation

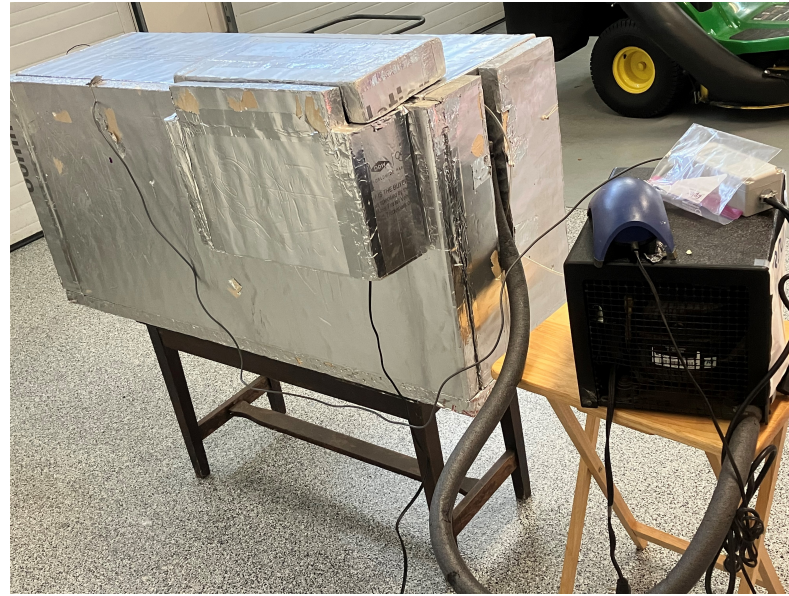


Finishing Touches

- Place digital thermometer sensor close to the breeder basket
- Test KH of water and adjust with baking soda, if needed, to assure tank KH reading is above 150 PPM
- Position front panel and install 4 anchor screws (1 – left side, 1 – left front, 1 – right side, 1 right front)
 - Attach rubber bands to each side to secure front panel
- Assemble gravel vac extender



The Finished Product



TIC EQUIPMENT SET-UP YEAR 2 & BEYOND

- Check tank support table to make sure it still supports 500 lbs (Ref slide 2)
- Clean gravel, filter and tank thoroughly (Ref slide 2)
- Replace the air stone and the check valve connecting all with air line tubing. Add weight to air stone, soak for at least 20 minutes and place on tank bottom (Ref slide 6)
- Repair any damaged insulation
- Assemble the filter with washed foam block on the bottom, two (2) new bags of washed 5 oz Chemi-pure in the middle and washed bag of BioMax on top (Ref slides 7-9)
- Hang filter on the back of the tank. Check the screen on the bottom of the intake tube and replace if necessary (Ref slide 10)
- Fill tank with water
- Fill filter cavity with water and plug filter into electrical source. Make sure water is moving through the filter (Ref slide 10)
- Position chiller arm and chiller sensor into appropriate position. Plug chiller into electrical source and make sure it is operation (Ref slide 11)
- After air stone has soaked for 20 minutes and locating it directly under the chiller coil plug air pump into electrical source (Ref slides 12 & 13)
- Place digital thermometer sensor into a convenient spot in tank (Ref slide 14)
- Test KH of water and adjust with baking soda, if needed, to assure KH reading is above 150 ppm (Ref slide 14)
- Attach breeder basket to the front edge of the tank at end away from the chiller coil (Ref slide 13)